

METAPLAST

The UK's fastest growing container manufacturer

5 Litre **AdBlue** Jerrycan with built in funnel

Product Specifications

Product Code: MP-K-5FL

AdBlue Stackable Jerrycan

Container

Weight:	140g (bottle & funnel) / 4.4g (cap)
Volume:	5 litres
Closure:	Ø38C or SK38/23 Bericap
Closing torque:	3-5Nm
Integral spout:	Funnel housed in can recess
Colours:	Natural bottle with blue funnel & cap (other colours available to order)

Palletisation

Jerrycans per pallet:	328
Full vehicle load:	33 pallets / 10,824 Jerrycans



Compatibility

The Metaplast **AdBlue** Jerrycan is specifically designed to hold diesel exhaust fluid (DEF) AKA **AdBlue**.

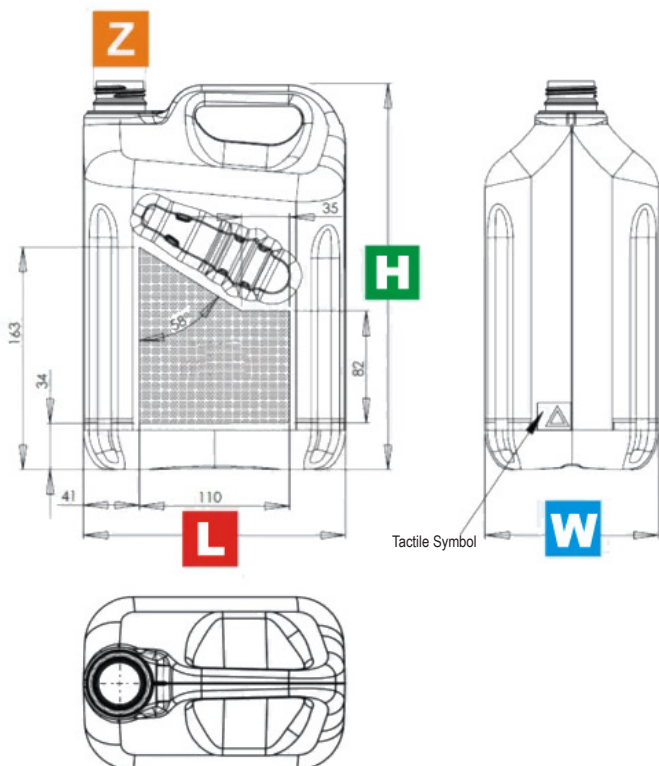

Manufacturers and Distributors of high quality plastic containers to the commercial sector

Metaplast Ltd

Unit A1, Ground Floor, Meridian House
Meridian Business Park, Norwich NR7 0TA

Tel: +44 (0)1508 495342

sales@metaplast.co.uk

www.metaplast.co.uk

While every care has been taken to ensure that product specifications are accurate, they are given for guidance only. For uses where specification is critical, customers are advised to check with Metaplast prior to purchase. We reserve the right to amend product specifications without prior notice.